

## ULTRA LOW CAPACITANCE TVS DIODE ARRAY

### Features:

- Ultra low leakage: nA level
- Low operating voltage: 3.3V
- Low clamping voltage
- Up to 4 lines protects
- Leadless flow-through package
- Complies with following standards:
  - IEC 61000-4-2 (ESD) immunity test  
 Air discharge:  $\pm 15\text{kV}$   
 Contact discharge:  $\pm 15\text{kV}$
  - IEC61000-4-5 (Lightning) 7A (8/20 $\mu\text{s}$ )
- RoHS Compliant

### Dimensions DFN2510-10

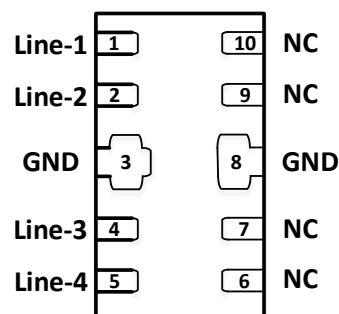

### Applications:

- High Definition Multi-Media Interface (HDMI) 1.3 & 1.4 version
- Display Port interface
- SATA and eSATA interface
- USB 3.0/3.1/3.2 Protection
- Digital Visual Interface (DVI)
- USB 2.0 up to 480Mb/s
- IEEE 1394 up to 3.2 Gb/s
- Ethernet port : 10/100/1000 Mb/s
- Desktop and Notebooks PCs
- Consumer Electronics
- Set Top Box

### Pin Configuration

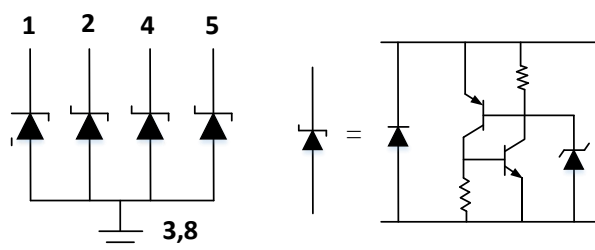

### Mechanical Characteristics

- Package: DFN2510-10 (2.5x1.0x0.5mm)
- Lead Finish: Matte Tin
- Case Material: "Green" Molding Compound.
- UL Flammability Classification Rating 94V-0
- Moisture Sensitivity: Level 1 per J-STD-020
- Terminal Connections: See Diagram Below
- Marking Information: See Below
- Device Marking: 33U/5ADP

**Absolute Maximum Ratings ( $T_A=25^{\circ}\text{C}$  unless otherwise specified)**

Parameter	Symbol	Value	Unit
Peak Pulse Power (8/20 $\mu\text{s}$ )	Ppk	28	W
Peak Pulse Current (8/20 $\mu\text{s}$ )	I <sub>PP</sub>	7	A
ESD per IEC 61000-4-2 (Air)	VESD	$\pm 15$	kV
ESD per IEC 61000-4-2 (Contact)		$\pm 15$	
Operating Temperature Range	T <sub>J</sub>	-55 to +125	$^{\circ}\text{C}$
Storage Temperature Range	T <sub>stg</sub>	-55 to +150	$^{\circ}\text{C}$

**Electrical Characteristics ( $T_A=25^{\circ}\text{C}$  unless otherwise specified)**

Parameter	Symbol	Min.	Typ.	Max.	Units	Conditions
Reverse Working Voltage	V <sub>RWM</sub>		3.3	5.0	V	Any I/O to Ground
Reverse Breakdown Voltage	V <sub>BR</sub>	6.0			V	I <sub>T</sub> =1mA, Any I/O to Ground
Holding Voltage	V <sub>H</sub>		1.6		V	I <sub>T</sub> =I <sub>H</sub>
Holding Current	I <sub>H</sub>		5		mA	
Reverse Leakage Current	I <sub>R</sub>			100	nA	V <sub>RWM</sub> =5V, Any I/O to Ground
Trigger Voltage	V <sub>T</sub>	7			V	Any I/O to Ground
Diode Forward Voltage	V <sub>F</sub>			1.2	V	I <sub>F</sub> =15mA, Ground to Any I/O
Clamping Voltage	V <sub>C</sub>		2.5		V	I <sub>PP</sub> =1A, tp=8/20 $\mu\text{s}$ , Any I/O to Ground
			4		V	I <sub>PP</sub> =7A, tp=8/20 $\mu\text{s}$ , Any I/O to Ground
Clamping Voltage	V <sub>C</sub>		3.7		V	I <sub>PP</sub> =4A, tp=TLP(Note1) Any I/O to Ground
			8.3		V	I <sub>PP</sub> =16A, tp=TLP(Note1) Any I/O to Ground
			2.9		V	I <sub>PP</sub> =4A, tp=TLP(Note1) Ground to Any I/O
			7.0		V	I <sub>PP</sub> =16A, tp=TLP(Note1) Ground to Any I/O
Junction Capacitance	C <sub>J</sub>		0.7		pF	V <sub>R</sub> =1.5V, f=1MHz, Any I/O to Ground
			0.35		pF	V <sub>R</sub> =1.5V, f=1MHz, between I/O pins

Note1: Non-repetitive current pulse, Transmission Line Pulse (TLP) tr=0.2ns, tp = 100 ns; square pulse

Typical Performance Characteristics ( $T_A=25^\circ\text{C}$  unless otherwise Specified)

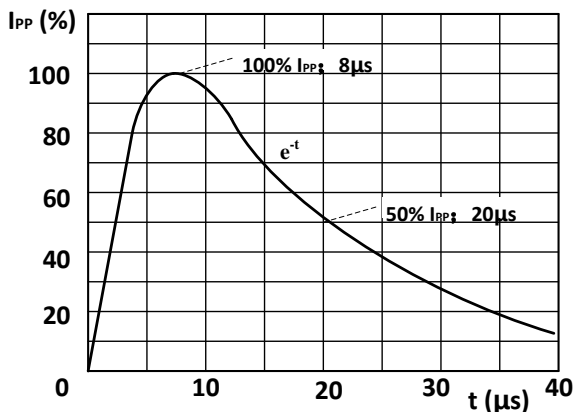

Fig. 1. 8/20  $\mu\text{s}$  pulse waveform according to IEC 61000-4-5 and IEC 61643-321

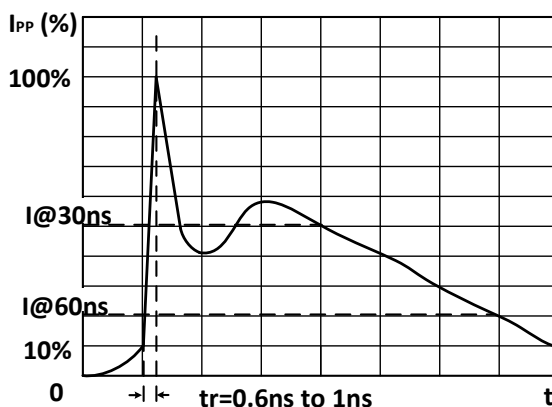

Fig. 2. ESD pulse waveform according to IEC 61000-4-2

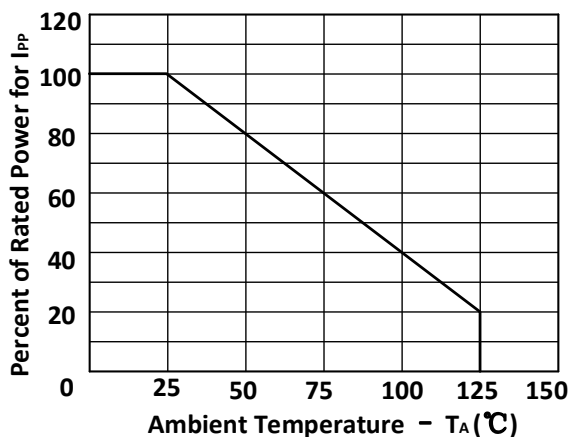

Fig. 3. Power Derating Curve

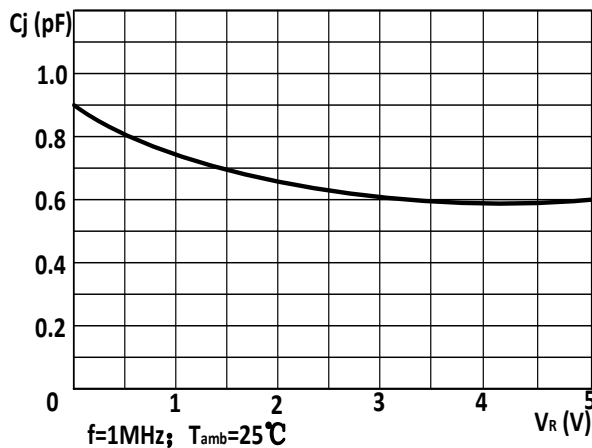

Fig. 4. Junction Capacitance vs  $V_R$

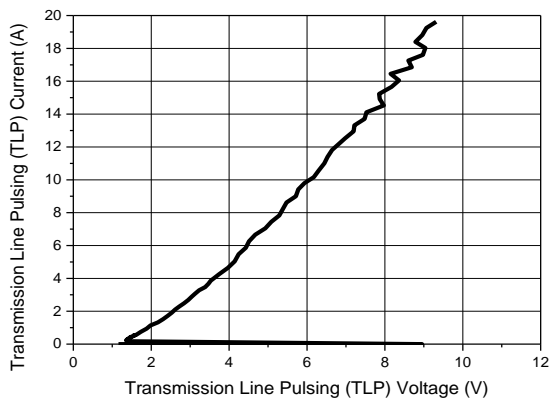

Fig. 5. Any I/O to Ground TLP Curve

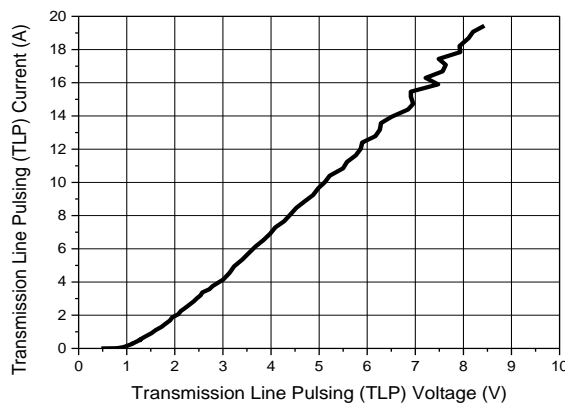
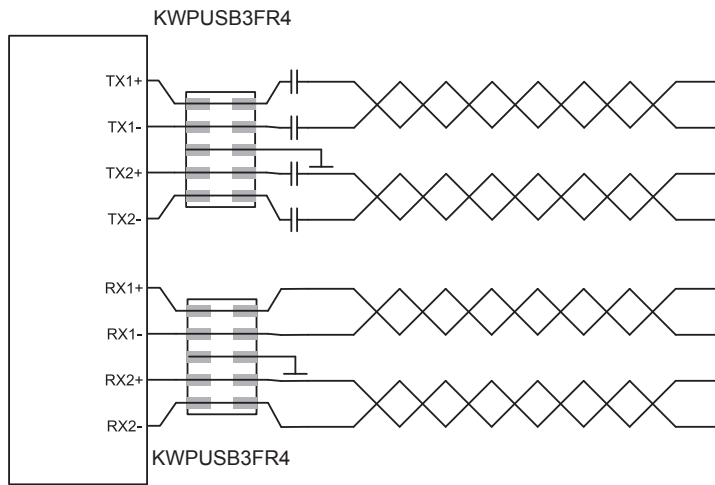
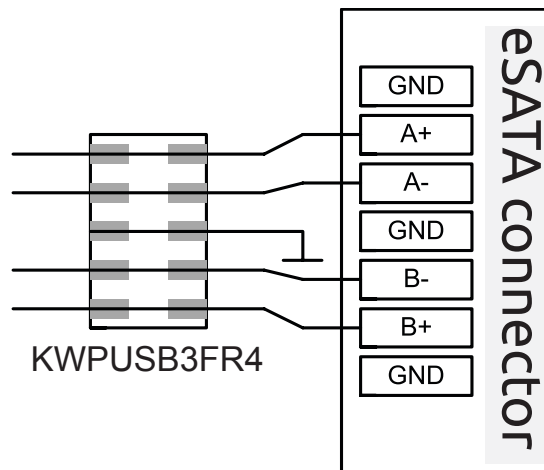

Fig. 6. Ground to Any I/O TLP Curve

High data-rate: USB 3.1



High data-rate: eSATA



eSATA ESD protection using KWPUSB3FR4

## High-speed differential mode signaling (LVDS, CML, TMDS, etc.)

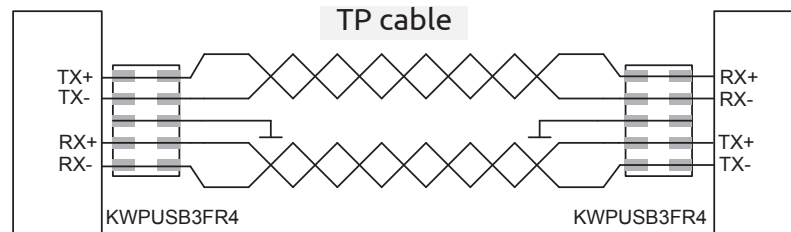

General high-speed differential mode signaling line ESD protection (actual data rate influences device choice)

**DFN2510-10 Package Outline Drawing**

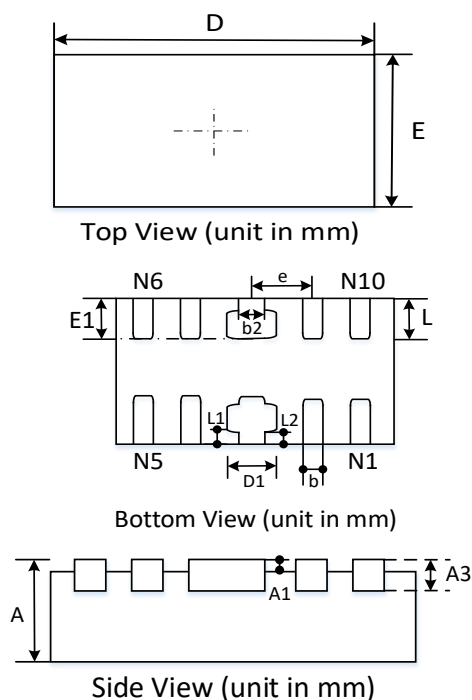

Symbol	Millimeters		Inches	
	min	max	min	max
A	0.40	0.55	0.016	0.022
A1	0.00	0.05	0.000	0.002
A3	0.152 REF		0.006 BSC	
D	2.45	2.55	0.096	0.100
E	0.95	1.05	0.037	0.041
D1	0.35	0.45	0.014	0.018
E1	0.35	0.45	0.014	0.018
b	0.15	0.25	0.006	0.010
e	0.05 BSC		0.019 BSC	
L1	0.075 REF		0.0029 REF	
L2	0.05 REF		0.0019 REF	
b2	0.20	0.30	0.0079	0.012
L	0.35	0.45	0.014	0.018

**\* SOLDERING FOOTPRINT**

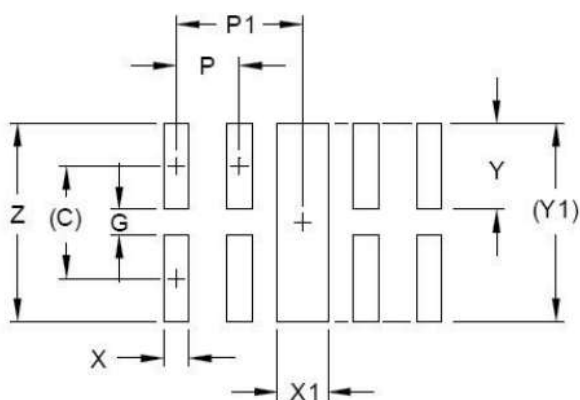

DIMENSIONS		
DIM	INCHES	MILLIMETERS
C	(.034)	(0.875)
G	.008	0.20
P	.020	0.50
P1	.039	1.00
X	.008	0.20
X1	.016	0.40
Y	.027	0.675
Y1	(.061)	(1.55)
Z	.061	1.55