

SUPER FAST RECOVER RECTIFIER

FEATURES

- Ultrafast 35ns Recovery Times
- High Voltage Capability to 400V
- Low Reverse Leakage Current

Marking

- MUR540

MAIN CHARACTERISTICS

I_O	5A
V_{RRM}	400V
T_j	150 °C
$V_{F(typ)}$	1.0V (@ $T_j=125^{\circ}C$)

TO-277

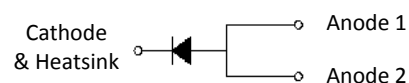
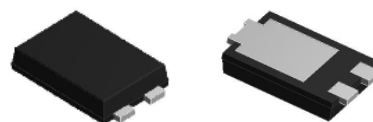

MAXIMUM RATINGS ($T_a=25^{\circ}C$ unless otherwise noted)

Symbol	Parameter	KMUR540	Unit
V_{RRM}	Peak repetitive reverse voltage	400	V
V_{RWM}	Working peak reverse voltage		
V_R	DC blocking voltage		
$V_{R(RMS)}$	RMS reverse voltage	280	V
I_O	Average rectified output current@ Total device	5	A
I_{FSM}	Non-Repetitive peak forward surge current 8.3ms half sine wave	90	A
$R_{\theta JC}$	Typical thermal resistance	3.5	°C/W
$R_{\theta JA}$	Thermal resistance from junction to ambient	52.5	
T_j	Operating Junction Temperature Range	-55 ~ +150	°C
T_{stg}	Storage Temperature Range	-55 ~ +150	°C

ELECTRICAL CHARACTERISTICS ($T_a=25^{\circ}C$ unless otherwise specified)

Parameter	Symbol	Test conditions	Min	Typ	Max	Unit
Reverse voltage	$V_{(BR)}$	$I_R=100\mu A$	400			V
Reverse current	I_R	$V_R=400V$	$T_j = 25^{\circ}C$	0.5	2	μA
			$T_j = 125^{\circ}C$		2.0	μA
Forward voltage	V_F	$I_F=5.0A$	$T_j = 25^{\circ}C$	1.0	1.25	V
			$T_j = 125^{\circ}C$			1.00
Typical total capacitance	C_{tot}	$V_R=4.0V, f=1MHz$		14		pF
Reverse recovery time	t_{rr}	$I_F=0.5A, I_R=1A, I_{rr}=0.25A$			35	ns

Typical Characteristics

FIG.1: FORWARD CURRENT DERATING CURVE

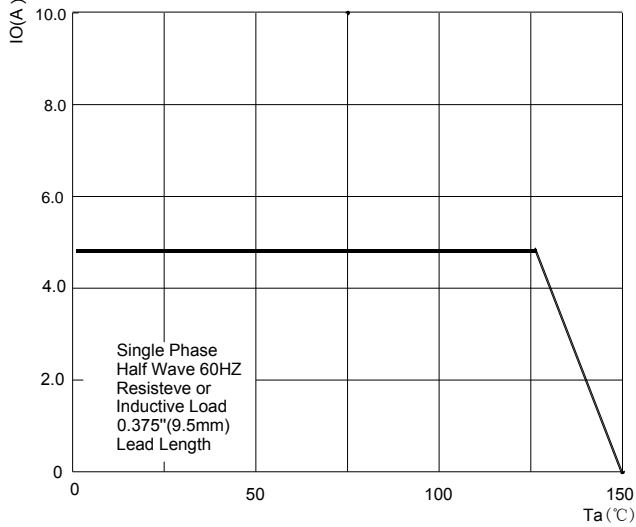
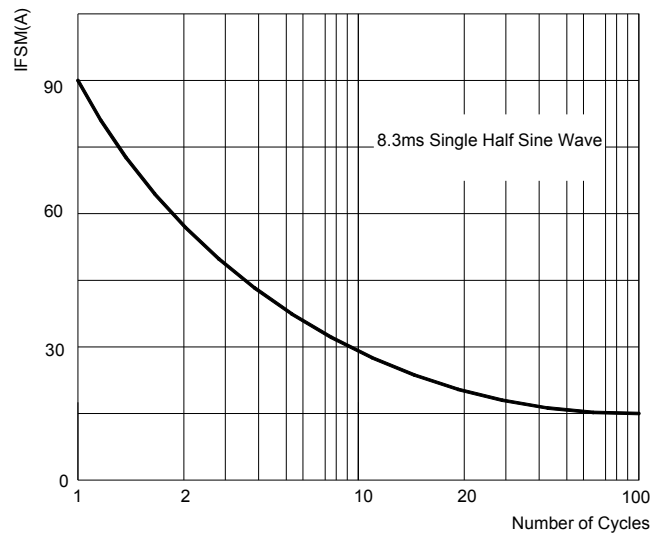

FIG.2: MAXIMUM NON-REPETITIVE FORWARD SURGE CURRENT



TYPICAL FORWARD CHARACTERISTICS

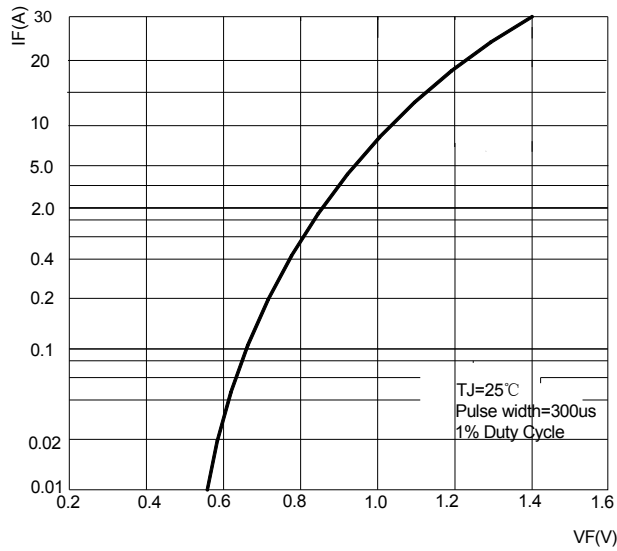

FIG.4: TYPICAL REVERSE CHARACTERISTICS

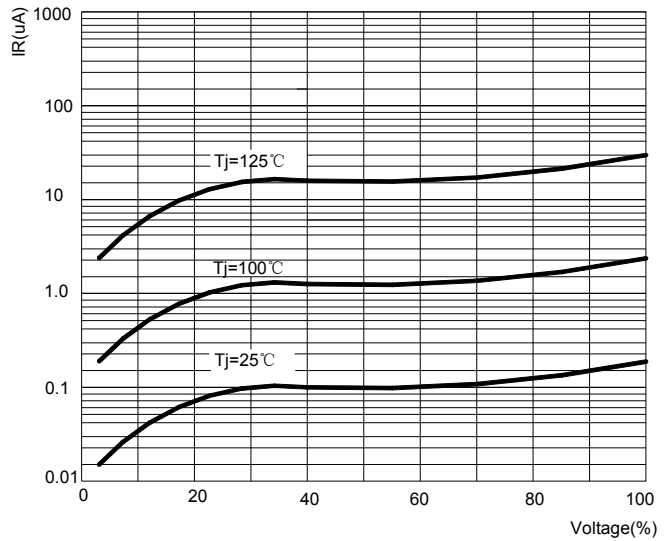
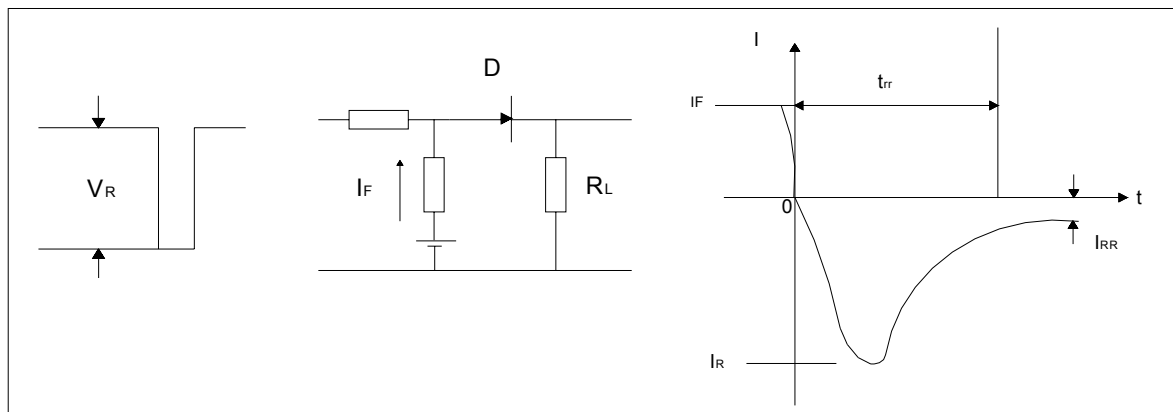
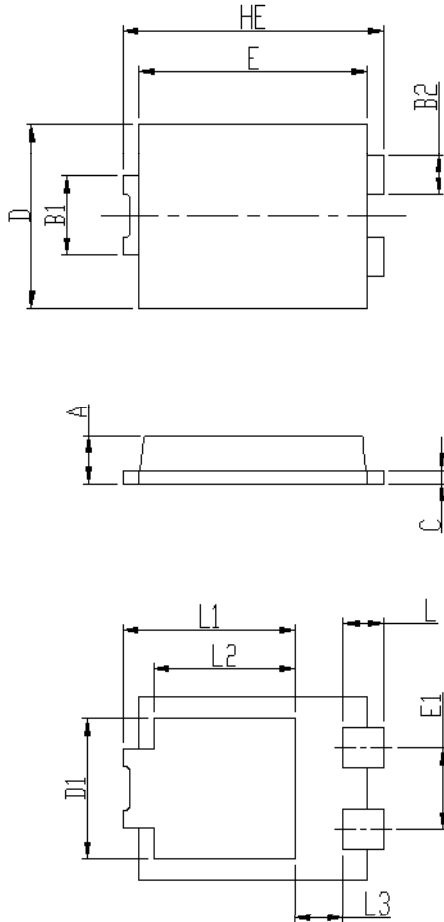

FIG.7: Diagram of circuit and Testing wave form of reverse recovery time



TO- 277 Package Outline Dimensions



DIM	Unit: mm		Unit: inch	
	MIN	MAX	MIN	MAX
HE	6.4	6.6	0.252	0.260
E	5.6	5.8	0.220	0.228
D	4.1	4.3	0.161	0.169
B1	1.7	1.9	0.067	0.075
B2	0.8	1	0.031	0.039
A	1.05	1.2	0.041	0.047
C	0.3	0.4	0.012	0.016
L	0.85	1.1	0.033	0.043
L1	4.2	4.4	0.165	0.173
L2	3.52 Typ.		0.139 Typ.	
L3	1.1	1.4	0.043	0.055
D1	3	3.3	0.118	0.130
E1	1.86 Typ.		0.073 Typ.	

TO- 277 Suggested Pad Layout

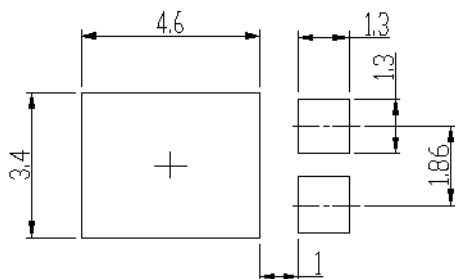

Note:

1. Controlling dimension: in millimeters.
2. General tolerance: ± 0.05mm.
3. The pad layout is for reference purposes only.